

## Viscosity Sensor M8B

### Introduction



#### WHY THE M8B?

- The sturdy measuring tube will support tank depth up to 72"
- Used in solvent-based application such as starch, paints, coating, and epoxy.
- The piston rod assembly is enclosed inside the support rod, and the fluid intake is at the bottom of the support rod.
- Works under atmospheric pressure.
- Flushing tube in the upper portion is connected to a pressurized solvent supply via a manually operated valve that allows for flushing of the inside of the tube during wash-downs.
- Optional circulating holes are furnished for applications not involving volatile solvents to permit free passage of liquid throughout the tube to prevent liquid from drying and building up inside the tube.
- It can be used with Norcross Viscosity Controller MP2000/MP2500 or VISC6000.

#### WHAT ARE THE SPECIFICATIONS?

Viscosity Range:	0.1- 100,000 cps
Tank Depth:	12" - 72" (305mm - 1829mm)
Temperature:	50°F - 250°F (10°C - 121°C)
Electrical:	Components are UL XP Class 1, Div 1, Group C, D M8BO requires a 3-way, 24vdc, 10 watts UL XP Air Valve (#08536)
Pneumatic Supply:	40psi (2.5 bar), dry air
Wetted Part:	Stainless Steel SS316
Solvent Valve:	If the system will be adding solvent, then a 2-way, 24vdc, UL XP Solvent Valve (#08537) is required

#### HOW DOES THE PISTON WORK?

- 1 A piston and piston rod shown at left is periodically raised by an air lifting mechanism, drawing a sample of the liquid to be measured down through the clearance between the piston and the inside of the cylinder into the space which is formed below the piston as it is raised.
- 2 The piston and piston rod are then allowed to fall by gravity, expelling the sample out through the same path as it entered. The 'Piston Time-of-Fall' is a measure of viscosity, with the clearance between the piston and the inside of the cylinder forming the measuring orifice.
- 3 NORCROSS Controller automatically measure this 'Piston Time-of-Fall' in order to record, indicate and control the viscosity.

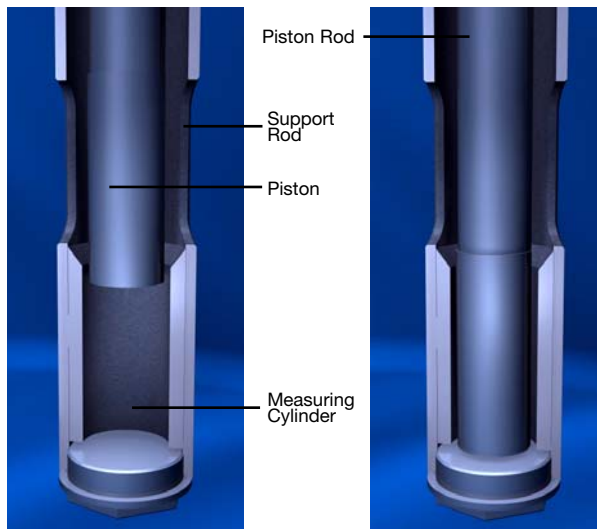

Filling Phase

Measuring Phase